

# MANUEL STEEL INDUSTRIES LLP

## MANUFACTURING PROCESS (HOT-ROLLED COILS & PLATES)

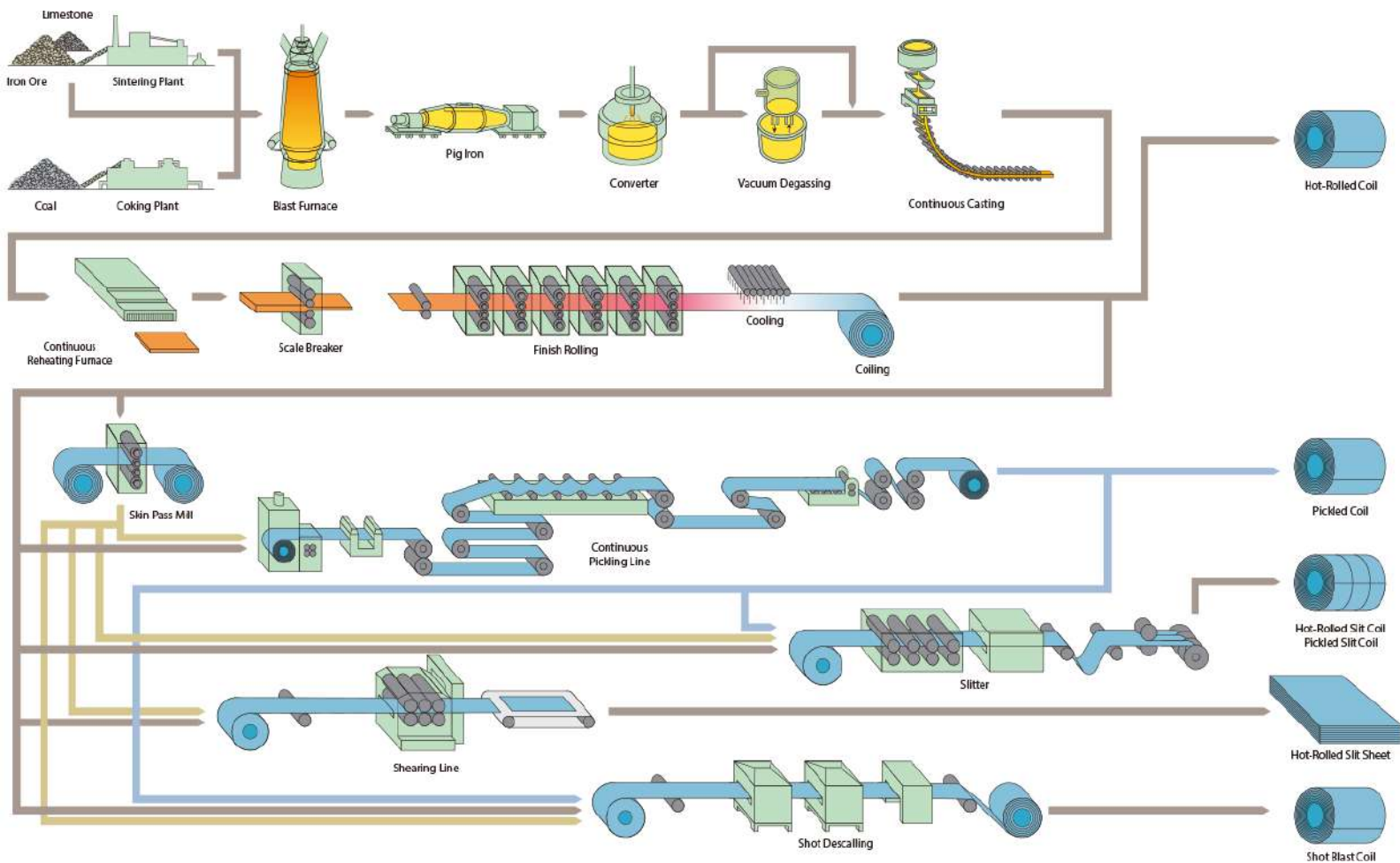

# MANUEL STEEL INDUSTRIES LLP

## MANUFACTURING PROCESS (COLD- ROLLED COILS & PLATES)

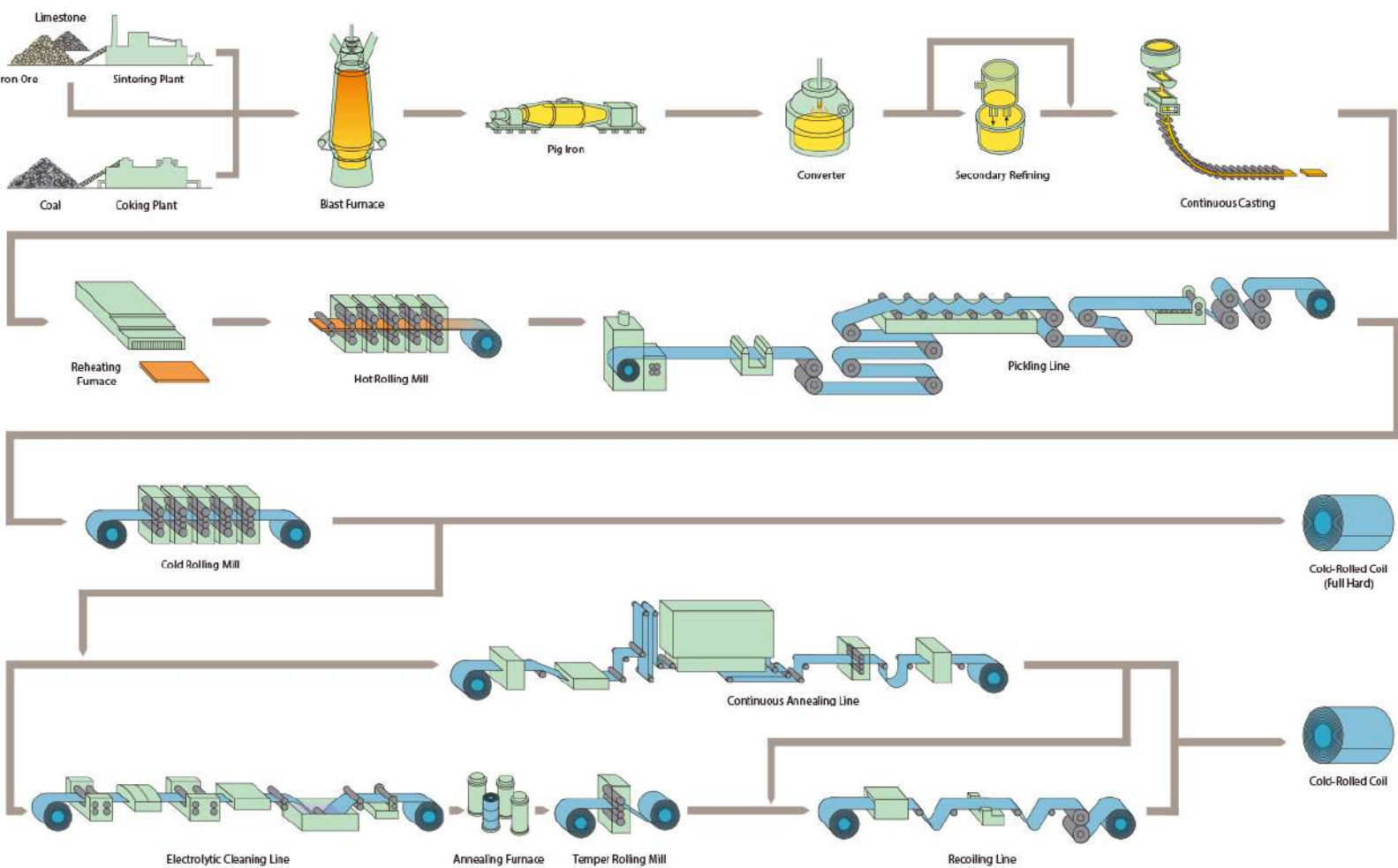

[sales@manuelsteel.com](mailto:sales@manuelsteel.com)

[www.manuelsteel.com](http://www.manuelsteel.com)

# MANUEL STEEL INDUSTRIES LLP

## MANUFACTURING PROCESS SEAMLESS PIPES (SMLS PIPES)

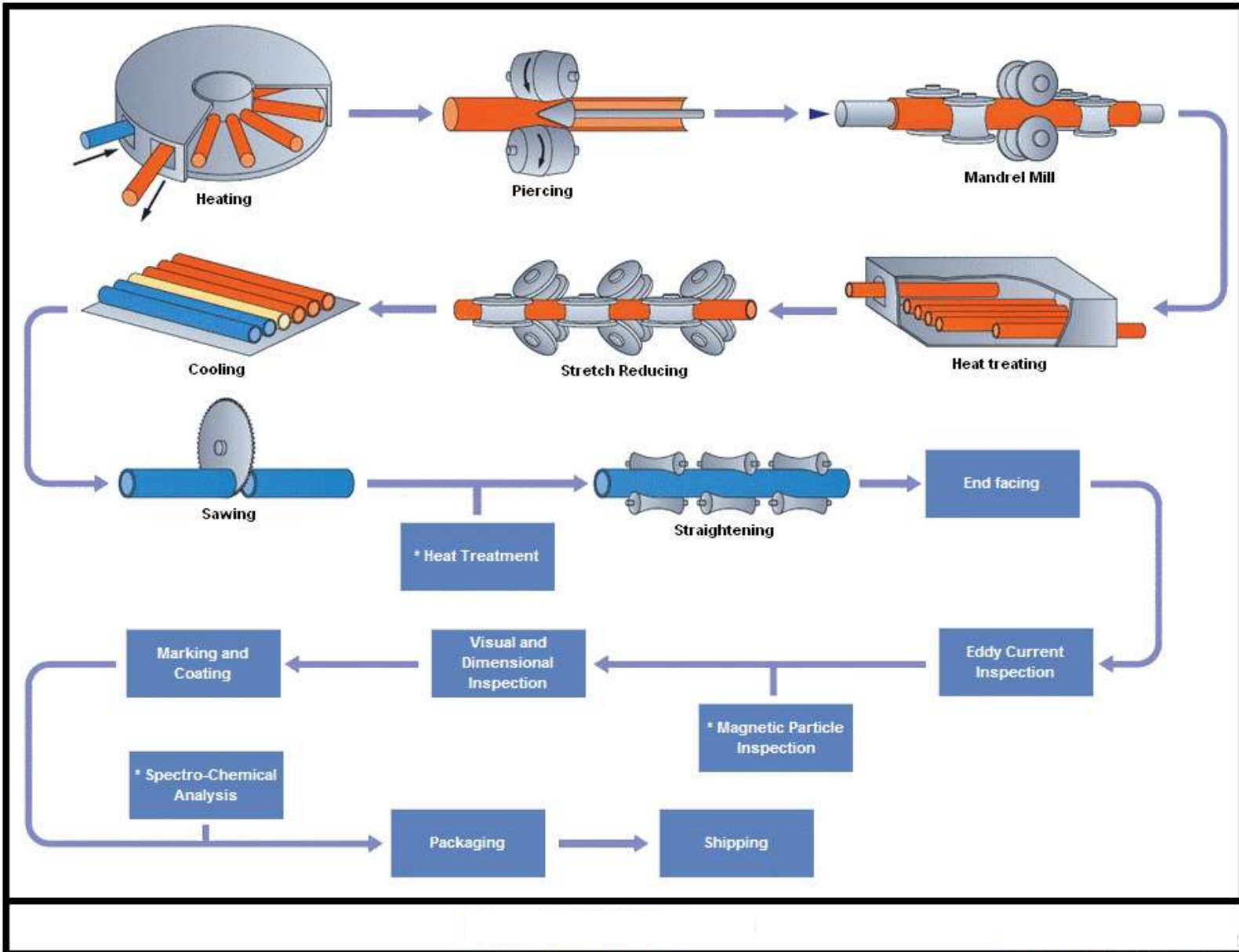

[sales@manuelsteel.com](mailto:sales@manuelsteel.com)

[www.manuelsteel.com](http://www.manuelsteel.com)

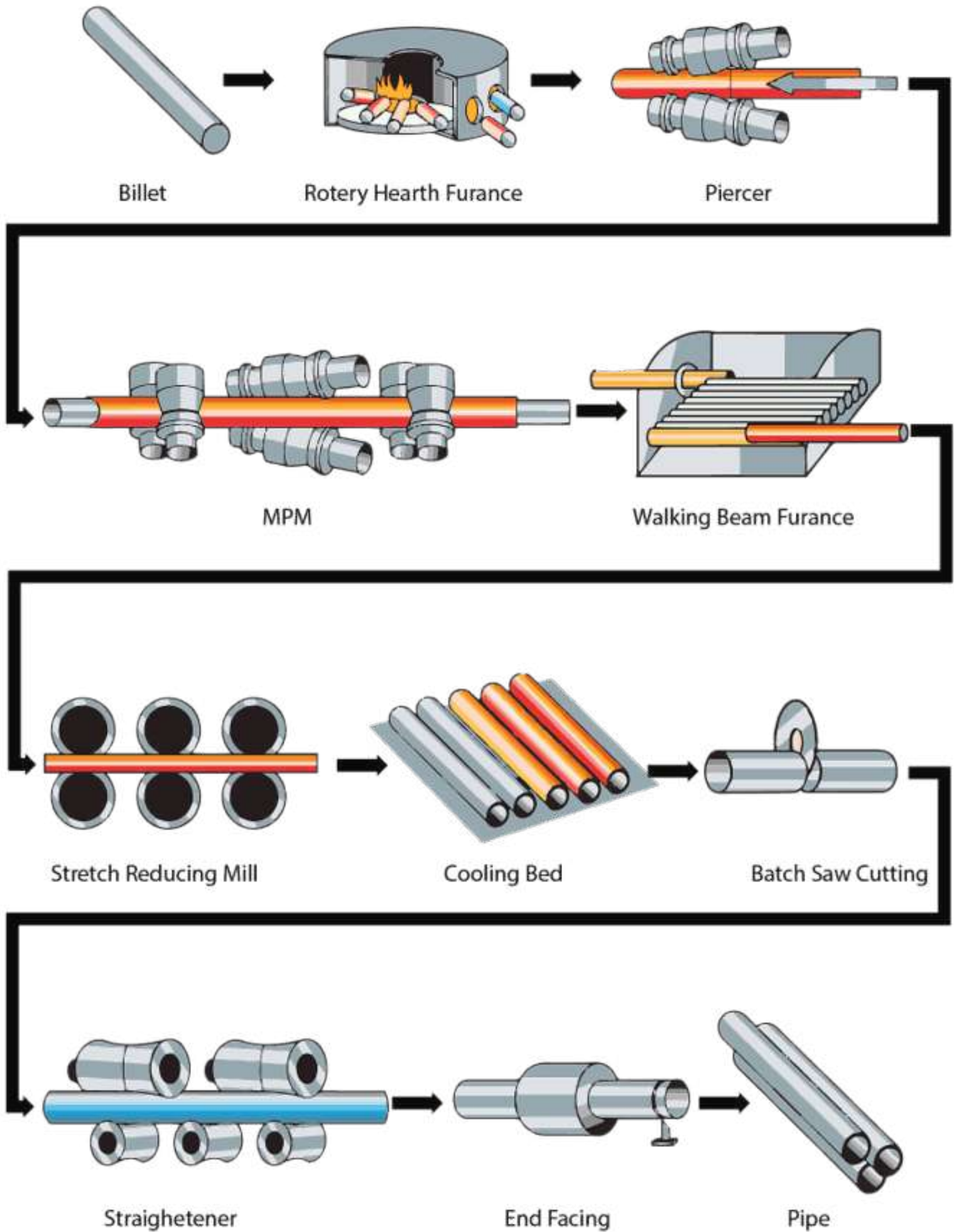

# MANUEL STEEL INDUSTRIES LLP

## MANUFACTURING PROCESS

(WIRE / WIRE RODS / WIRE RODS IN COIL FORM)

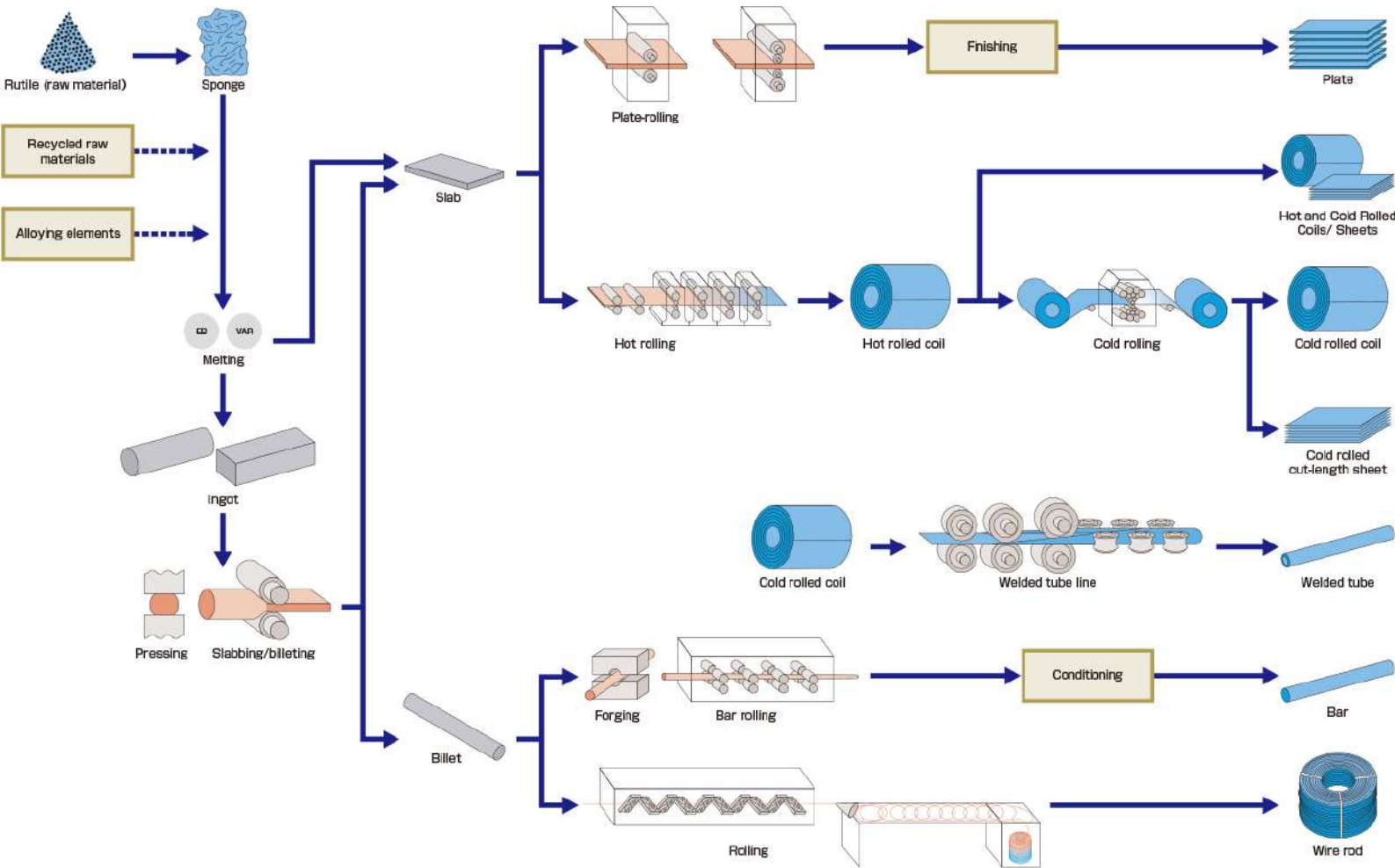

[sales@manuelsteel.com](mailto:sales@manuelsteel.com)

[www.manuelsteel.com](http://www.manuelsteel.com)



# MANUEL STEEL INDUSTRIES LLP

## MANUFACTURING PROCESS

### (HOT ROLLED BARS)

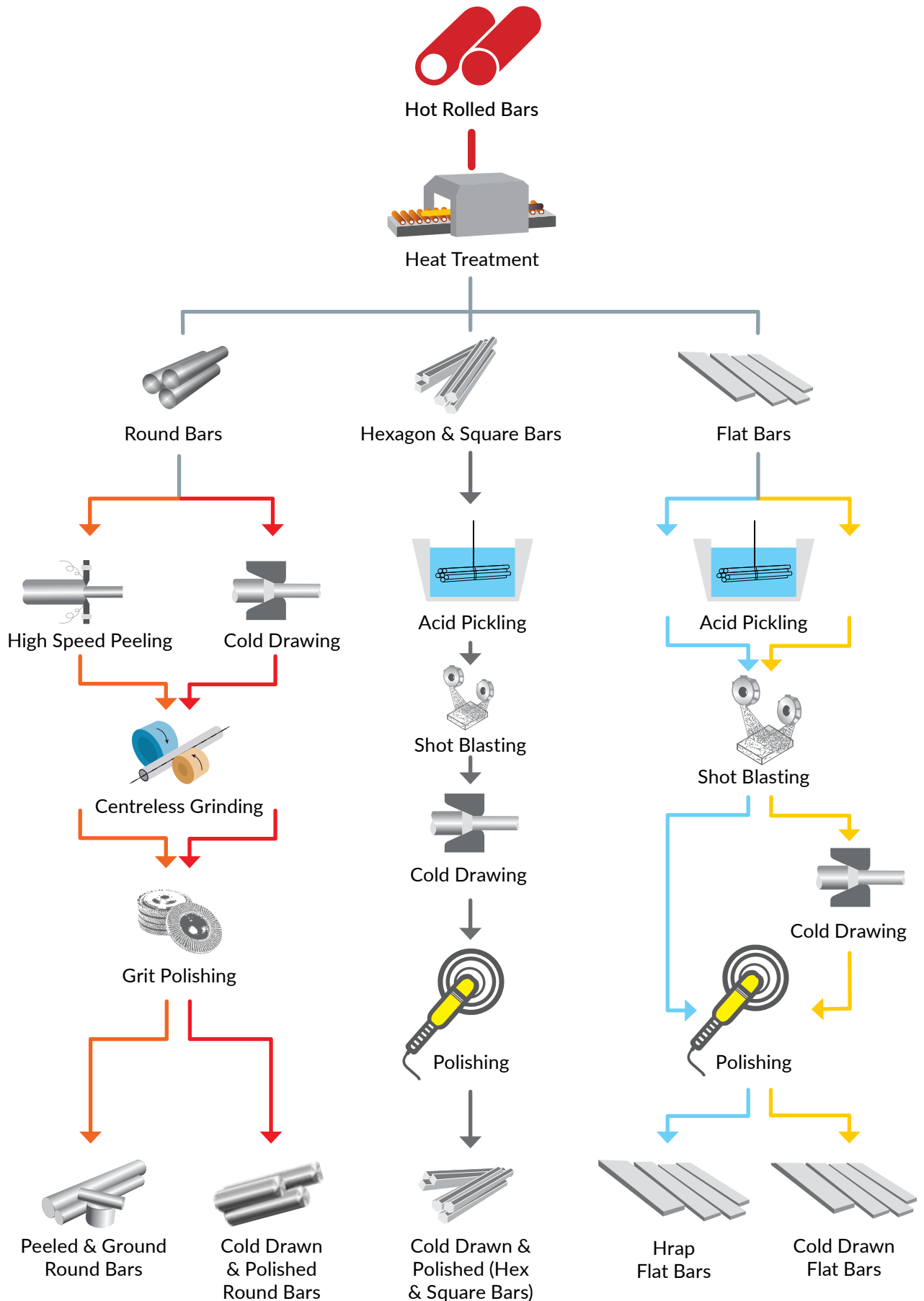

# MANUEL STEEL INDUSTRIES LLP

## MANUFACTURING PROCESS

### (COLD ROLLED BARS)

